

**KEY NOTES**

- 03 Stone liner block
- 04 Dimension stone wall cladding
- 08 Light gauge steel stud framing
- 19 Anchoring plate
- 27 Gypsum board
- 32 L-strap anchor
- 35 Drill to depth to accept dowel
- 37 Dowel
- 77 Bearing pad, plastic or non-compressible rubber
- 78 Shim as required

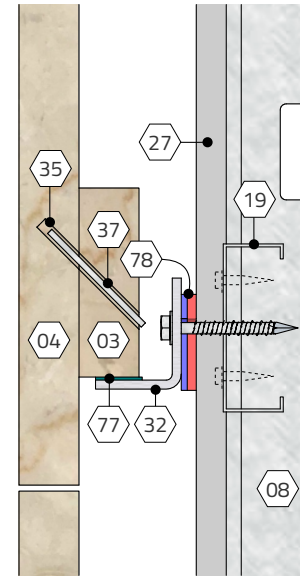
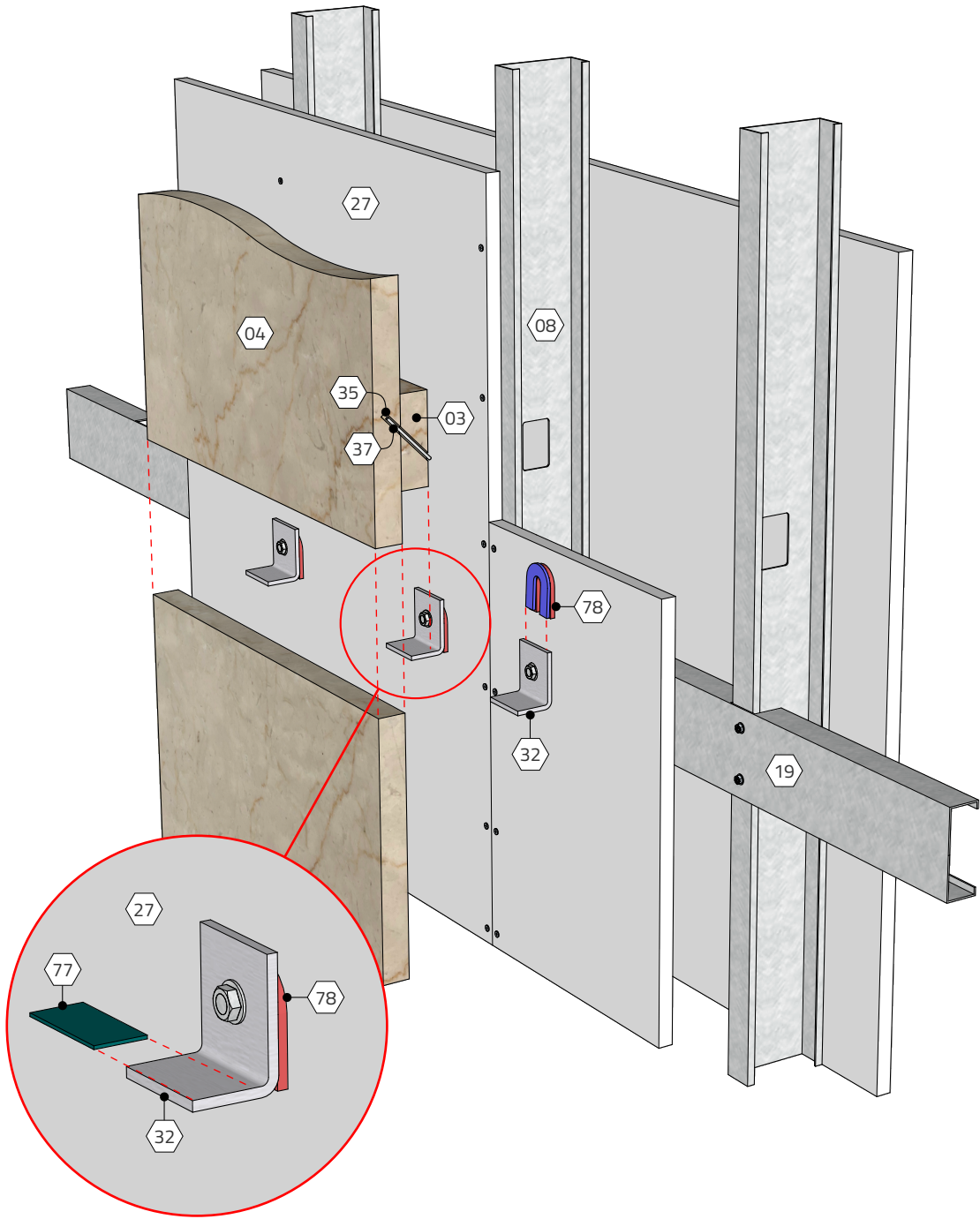

Section  
Scale: 3" = 1'-0"

**KEYWORDS**

Marble, Dimension stone, Interior, Walls, Anchored, L-strap, Liner block, 04.040.0204

TITLE

Dimension stone wall, interior | L-straps with liner block epoxied and doweled into stone

SCALE

Noted

REV.

11/18/22

SHEET NO.

04.040.0204